

# Replacement of Mandrel

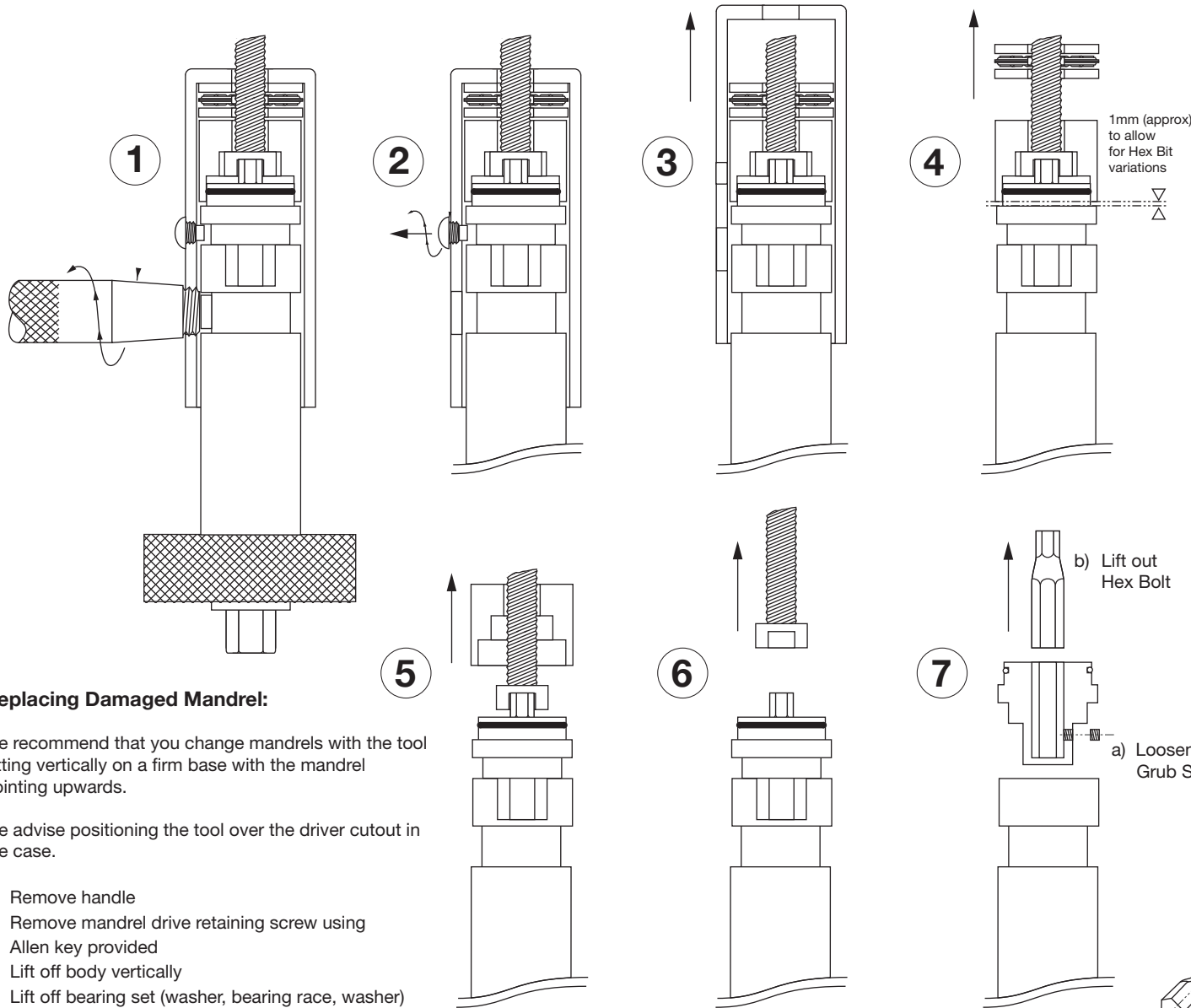

## Replacing Damaged Mandrel:

We recommend that you change mandrels with the tool sitting vertically on a firm base with the mandrel pointing upwards.

We advise positioning the tool over the driver cutout in the case.

1. Remove handle
2. Remove mandrel drive retaining screw using Allen key provided
3. Lift off body vertically
4. Lift off bearing set (washer, bearing race, washer)
5. Remove mandrel support boss
6. Lift off mandrel carefully and replace with new mandrel
7. To Change/replace Hex Bit if required remove the Hex Grub Screw retaining the Hex Bit
8. Re-assemble in reverse order

Note: Apply oil or grease to bearing set during re-assembly  
Lubricate mandrel regularly. We recommend Finish Line Extreme Fluoro Lubricant  
Mandrel Driver and Hex Bit can be left in situ

## RNHT 48/410 Replacements Components List

HEX BIT SPECIFICATION:  
Hex Bit 1/4" Drive, 25mm Long, Across Flats Dimension

METRIC THREAD	M4	M5	M6	M8	M10
HEX BIT	3mm	4mm	5mm	6mm	8mm

IMPERIAL THREAD	8	10	1/4	5/16	3/8
HEX BIT	9/64	5/32	3/16	1/4	5/16

Fastener Material	Steel, Aluminium, Stainless Steel
Installation Key	Steel & Aluminium only

SOCKET HEAD CAP SCREW SPECIFICATION:  
DIN 912 12.9 Socket Head Cap Screw

### APPLICABLE FASTENERS:

Rivet Nuts  
Screw Anchors/Jack Nuts  
Swaging Inserts

### SCREW LENGTHS:

Short/1st Grip Screw Length Requirements (Standard Kit Parts)

METRIC	M4	M5	M6	M8	M10
UNC	8'32	10'24	1/4-20	5/16-18	3/8-16
UNF	8'36	10'32	1/4-28	5/16-24	3/8-24
Screw Length	30mm	30mm	35mm	35mm	40mm

Long/2nd Grip Screw Length Requirements

METRIC	M4	M5	M6	M8	M10
UNC	8'32	10'24	1/4-20	5/16-18	3/8-16
UNF	8'36	10'32	1/4-28	5/16-24	3/8-24
Screw Length	35mm	35mm	40mm	40mm	45mm

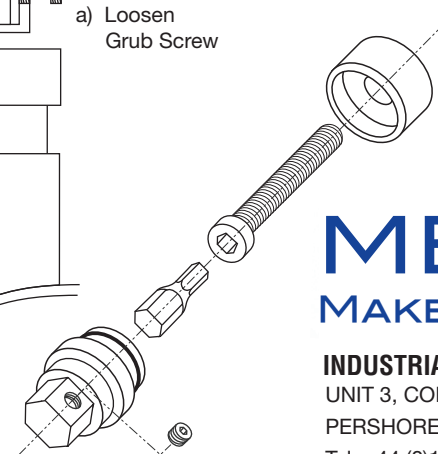

# MEMFAST

MAKE ENDS MEET LTD

**INDUSTRIAL FASTENING SYSTEMS & TOOLING**  
UNIT 3, COLOUR BLOCK, RACECOURSE ROAD,  
PERSHORE, WORCESTERSHIRE WR10 2EY  
Tel: +44 (0)1386 556868 Fax: +44 (0)1386 556868  
Email: info@memfast.co.uk www.memfast.co.uk